

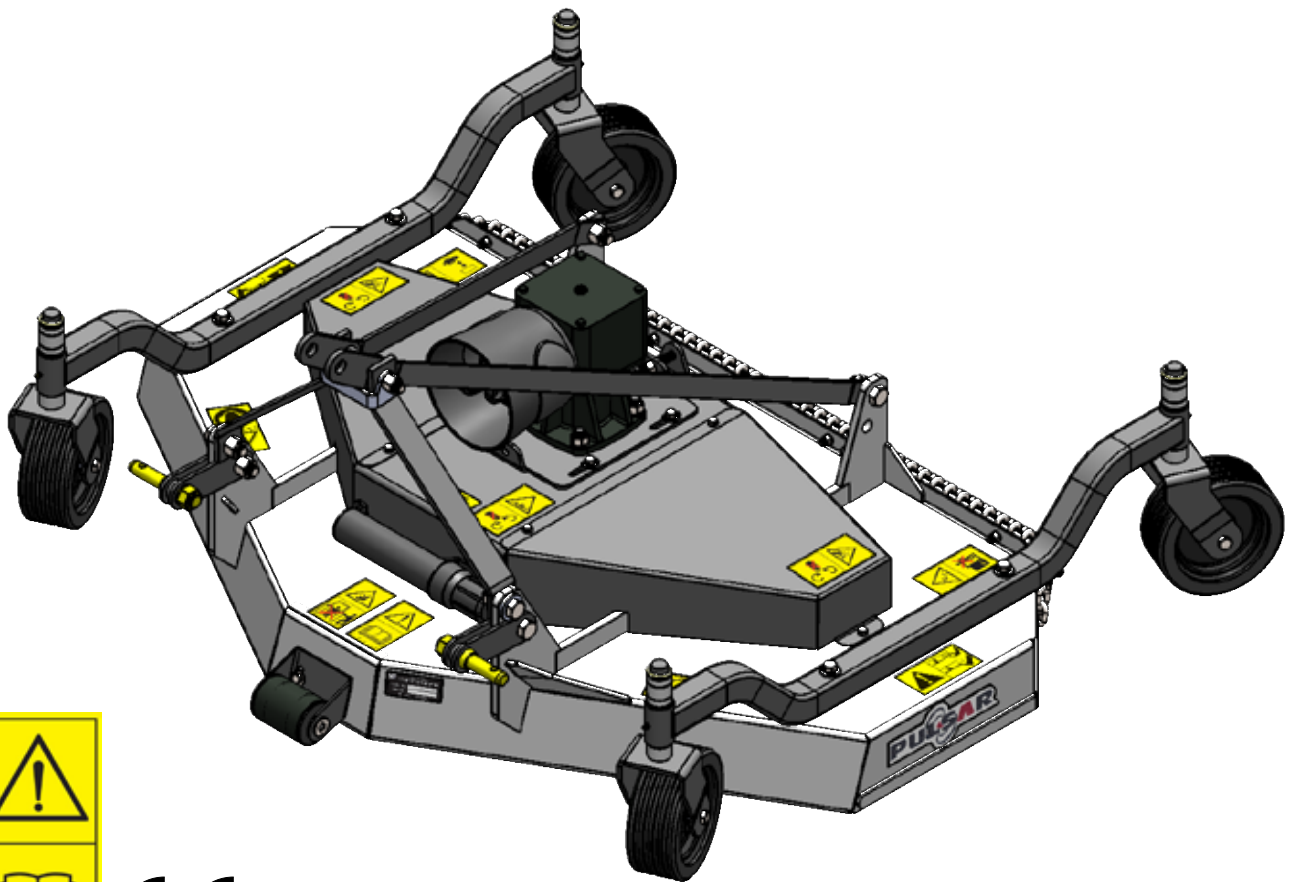

## Pulsar Finishing Mower Operator's / Parts Manual



MK Martin Enterprise Inc.  
3950 Steffler Rd Elmira, ON, Canada N3B 2Z3

Tel: 519-664-2752  
Toll Free: 1-855-664-2752  
Fax: 519-664-3695  
E-mail: [sales@mkmartin.ca](mailto:sales@mkmartin.ca)  
[www.mkmartin.ca](http://www.mkmartin.ca)



REV: 20-3



## Table of Contents

Warranty	-----	2
Registration	-----	3-4
Safety	-----	5-6
Assembly	-----	7
Decal Location	-----	8-9
Operation	-----	10-11
Sign Off Form	-----	12
48 - 72 Parts	-----	13-16
90 Parts	-----	16-17
Deflector Parts	-----	18
Belt Arrangement	-----	19
Gearbox	-----	20-21
PTO Driveline Dimensions	-----	22
PTO	-----	23-25
Bolt Torque Chart	-----	26
Maintenance	-----	27



3950 Steffler Rd. • Elmira • Ontario, Canada • N3B 2Z3 • Email : sales@mkmartin.ca • Fax : (519)-664-3695 • Tel : (519)-664-2752

# Warranty

Effective on products retailed on or after November 1, 2017

## Two Year Limited Consumer Warranty

## Five Year Limited Consumer Warranty on Gearboxes

## 90 Day Limited Commercial Warranty including Gearboxes

Commercial includes rental and industrial applications.

**Warranty begins at the time of customer delivery and is activated upon warranty registration receipt at MK Martin Enterprise Inc.**

**Warranty coverage is null and void unless the Warranty Registration form has been completed in full and is on file at MK Martin Enterprise Inc.**

**Keep your registration copy in a safe place, it is required as proof of warranty activation.**

This new and unused product is warranted by MK Martin Enterprise Inc. to be free from defects in material and workmanship under normal use and regular service as described in the owner's manual, for a consumer period of 2 years and 5 years for gearboxes, from the date of delivery, and commercial period of 90 days, including gearboxes, from the date of delivery. Warranty is limited to the replacement of parts and / or repair of the product.

If issues develop within the warranty period with the product, contact the local dealer from which you purchased the unit. Only MK Martin authorized dealers may make repairs to the product or affect the replacement of defective parts, unless otherwise approved by MK Martin. Repairs / replacement will be done at no charge within a reasonable time after the receipt of the product.

**This warranty does not cover the following items:**

1. Normal replacement of service items.
2. Normal maintenance or adjustments.
3. Machines or parts lost or damaged during shipment,
4. Accessory items / parts not supplied by MK Martin
5. Damages resulting from:
  - misuse, negligence, accident, theft or fire
  - use of improper or insufficient fuel, fluids or lubricants
  - use of after market parts or accessories, unless approved by MK Martin
  - modifications, alteration, tampering or improper repair
  - any device or accessories installed by other than an authorized dealer.
6. Tires are covered by the manufacturer of the tire and the warranty period specified by that manufacturer. **Please contact the tire manufacturer for warranty on these items.**

MK Martin Enterprise Inc. shall not, in any event, be liable for any losses, damages or costs; to include profits, travel, transportation, pick up, delivery, towing cost, tow vehicle, loss of use, whether special, incidental, consequential or otherwise, in any way. Unit or parts are returned at the customer's expense.

Include a copy of your completed Warranty Registration form with any claim as proof of warranty activation.

There are no warranties, expressed or implied, other than those specified herein. No agent, employee or other person has any authority to vary any of the foregoing provisions.

Warranty coverage is null and void unless the Warranty Registration form has been completed in full and is on file at MK Martin Enterprise Inc. Warranty begins at the time of customer delivery and is activated upon Warranty Registration receipt at MK Martin Enterprise Inc.

**M K Martin Enterprise Inc  
3950 Steffler Rd  
Elmira ON CA N3B 2Z3**

*Purchaser's warranty protection is valid only when this completed form or a copy of this form is on file at M K Martin Enterprise Inc. By filling out this form the purchaser has acknowledged delivery of equipment and owner's / operator's manual and has accepted the condition of the equipment.*

**Date of delivery to purchaser** -----

**Type of Equipment** -----

**Model #** ----- **Serial #** -----

**Retailer's Signature Indicates**

- *Equipment was properly assembled as directed by manufacturer*
- *Equipment was tested for functionality and operates properly*
- *Purchaser was instructed in safe and proper operating procedures*
- *Warranty was explained to purchaser*
- *Purchaser was given the operators manual*

***Retailer***

**Signature** -----

**Company** -----

**Address** -----

-----

**Purchaser's signature indicates**

- *Acceptance of equipment fully assembled*
- *Received operator's manual*
- *Clearly understands conditions of warranty*
- *Received instructions of safe and proper operation of equipment*

***Purchaser***

**Signature** -----

**Company** -----

**Mailing address** -----

**City** ----- **Prov/State** ----- **Postal Code/Zip** -----

**Available phone number** -----

**Warranty is valid only when it has been received by manufacturer at address above**

# Warranty Registration

**Please Cut and Return to M K Martin Enterprise Inc**

**Fold And Tape here**

*Do not tape all edges or use staples*

*Fold Here*

**Postage  
Stamp**

**M K Martin Enterprise Inc  
3950 Steffler Rd  
Elmira ON CA N3B 2Z3**

## Safety

**Take Note!** This safety symbol is found throughout this manual to call your attention to instructions involving yourself and others working around the machine.

- **Failure to follow these instructions can result in injury or death**



This symbol means

- **Attention!**
- **Become Alert!**
- **Your Safety is involved!**

Signal words are used in this manual.

**Caution:** Indicates a potentially hazardous situation that may result in injury.

**Warning:** Indicates a hazardous situation that could result in serious injury or death.

**Danger:** Indicates a hazardous situation that needs to be avoided. It is you the operator that needs to be aware of these dangers.

If you have any questions not answered in this manual please contact your dealer or

M K Martin Enterprise Inc  
3950 Steffler Rd  
Elmira On Ca N3B 2Z3

Tel: 519-664-2752  
1-855-664-2752  
Fax: 519-664-3695  
e-mail [sales@mkmartin.ca](mailto:sales@mkmartin.ca)

[www.mkmartin.ca](http://www.mkmartin.ca)



## **Safety -- It's in your interest!**

1. Read and understand the Operator's Manual and all safety signs before operating, servicing, adjusting, repairing or unplugging.
2. Do not allow riders.
3. Install and secure all guards and shields before operating the equipment.
4. Keep hands, feet, hair and clothing away from all moving parts.
5. Place all controls in neutral, stop tractor engine, set park brake, remove ignition key and wait for all moving parts to stop before servicing, adjusting, repairing or unplugging the mower.
6. Place all tractor controls in neutral before starting.
7. Never operate the mower unless you are sitting on the tractor seat.
8. Do not operate the tractor inside a building unless there is adequate ventilation.
9. Clear the area of bystanders, especially small children before starting.
10. Stay clear of the machine when engaging the PTO. Keep others away.
11. Clean reflectors, SMV sign and lights if used, before transporting.
12. When transporting use hazard flashing lights.
13. Do not put hands or feet under machine while tractor engine is running.
14. Do not operate the mower in a raised position.
-  15. Objects can be thrown out from the mower with sufficient force to severely injure people or pets. Stay away from mower when it is running, keep others away.
16. Remove all sticks, stones and other loose matter in the area before starting.
17. Review operator's manual annually.



**It is the responsibility of the owner or operator to read this manual and to train all other operators before they start working with the mower.**



**Follow all safety instructions. Safety is everyone's business. By following recommended procedures, a safe working environment is provided for the operator, bystanders and the area around the work-site.**



**Untrained operators are not qualified to operate the mower!**



## Assembly Information

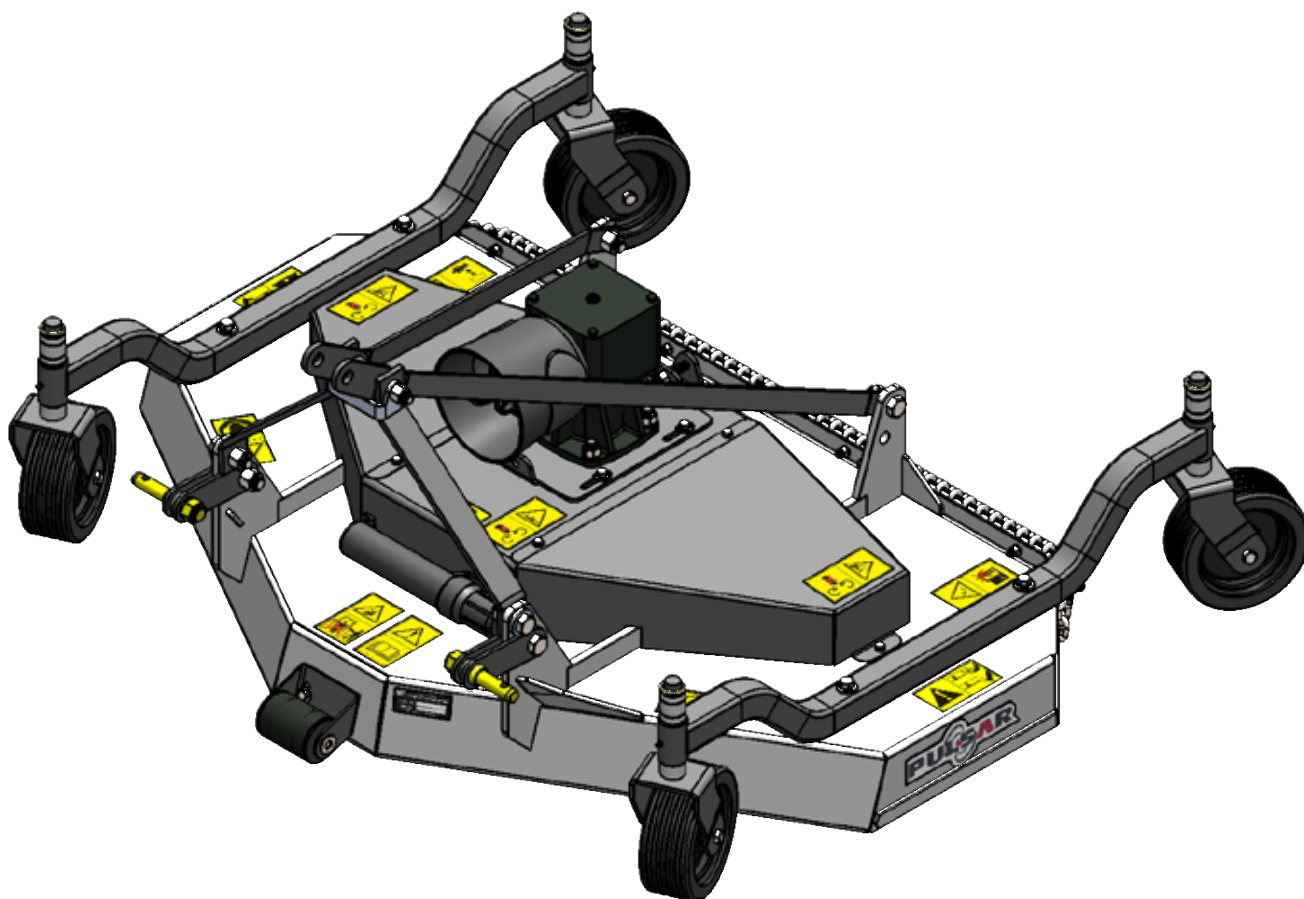

These Finish Mowers are shipped with the “A” Frame disassembled.

Assemble by undoing the top “A” Frame bolt and inserting the Brace Bars as shown above.

After tightening the nut on the bolt, back the nut off 1/3-1/2 turn to allow some movement in the linkage.

Ensure the Anti-Scalp roller turns free, a few drops of oil may be added on the axle shaft at this time.

Ensure the wheels and the caster pivot turn freely. Lightly grease the caster pivot.



**When attaching Mower to tractor ensure drive-line is the right length and does not bind.**  
(See page 22 for directions)

## Decal Location

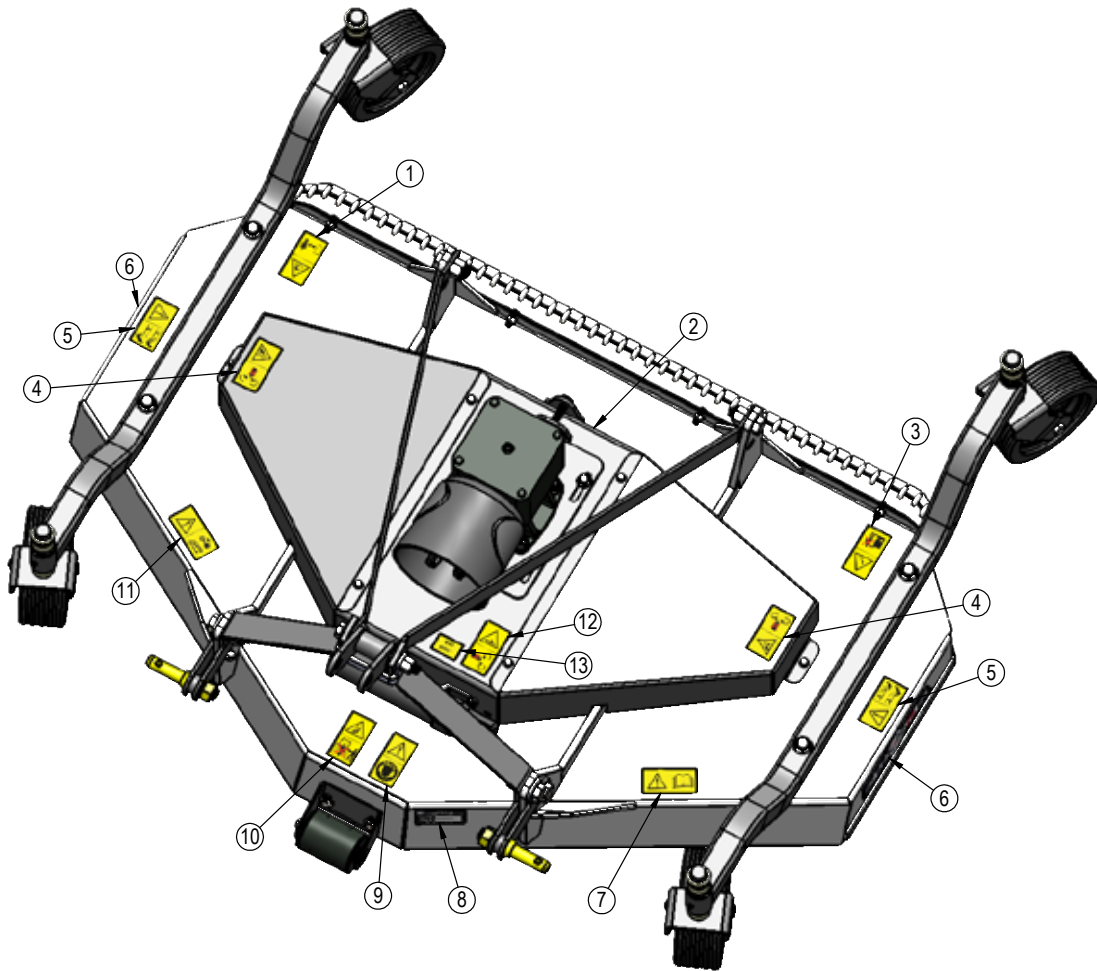

6 - Part # PULSAR  
- x2



2 - Part #  
MKlogomadeincanada



8 - Serial Plate



1 - Part # 224

**DANGER.** Sharp objects could be thrown. Keep safe distance from the machine



3 - Part # 227

**Danger** of dropping. Do not climb on to the machine.



4 - Part # 211 - x2

**Risk of injuries.** Do not remove the protective shields from the belts unless all moving parts of the machine have reached a complete standstill.



5 - Part # A75 - x2

**DANGER** of possible shearing of limbs. Keep a safe distance from the machine while it is working.

## Technical Data

MOD.	Cut Width	HP	# Blades	RPM	Weight (lbs.)
Pulsar 48 rear	48	14-20	3	540	365
Pulsar 60 rear	60	14-22	3	540	425
Pulsar 72 rear	72	18-25	3	540	520
Pulsar 90 rear	90	30-40	5	540	680

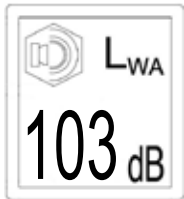

### Noise Level

No- load noise detection  
 Level of acoustic pressure L<sub>pA</sub> dB - - - - 94 dB  
 Level of acoustic power L<sub>WA</sub> dB - - - - 103 dB



7 - Part # F9

**Before operating machine**, carefully read the instruction manual



9 - Part # Noise

**Loud noise.** Wear adequate hearing protection, e.g. headphones.



10 - Part # 207

**DANGER of being crushed.** Do not get between the tractor and the machine.



11 - Part # 226

**Before any operation of maintenance** a/o adjustment, stop, brake the tractor on level ground, lower the machine to the ground and read the instruction manual.



12 - Part # 220

**DANGER of being caught by the PTO shaft.** Do not go near the rotating members of the machine while in operation.

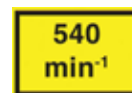

13 - Part # 540

Operate with PTO at 540 RPM

## Operating

### For the new operator

This finish Mower is designed to cut a variety of grasses. The mower will work best on dry grass. When cutting damp or long grass, use slower travel speed and you may need to frequently clean the underside of the mower deck. Power to the blades is provided by the tractor through a PTO Shaft, Gearbox and Belts.

This mower is designed for a 540 RPM PTO speed and will give the best performance at this speed.

Many features in this mower are the result of suggestions made by customers like you.

By following the operating instructions in conjunction with a good maintenance program, your Pulsar Finish Mower will provide you with many years of service.

### To Operate

Attach the mower to the tractor 3ph. Ensure the deck is level to the ground by adjusting the right hitch arm adjustment and the top link until the deck is level.

Cutting height is controlled with spacers on the caster pivot. Move spacers from top to bottom of wheel beam or bottom to top as needed for the proper cutting height.

### Starting the Mower

With the mower slightly raised from the ground. (wheels may be off the ground 3-6 inches)

Run the engine at a slow speed and slowly engage the PTO.

Slowly bring the engine to PTO speed. Do not exceed rated speed.

Lower the mower to the ground and proceed to mow.

### Ground Speed

Travel speed can vary between 1 and 4 mph (1.5 and 6km/h) depending on the grass and terrain conditions. It is the responsibility of the operator to note the conditions of the job being done and to set the speed to obtain a quality cutting job while maintaining control of the equipment.

The speed can be increased for lighter cutting conditions.

Decrease your speed if the cut is ragged and uneven, or uncut patches.

### Transport on Road - Be Safe, Be Seen!

When driving on the road please follow all regulations. Use lights, reflectors, SMV sign as required by law.

## Wheel Height

When setting the height of the deck, follow this procedure:

1. Clear the area of bystanders, especially children.
2. Raise the 3 point hitch or lift with a hoist until the wheels are far enough off the ground to remove the casters.
3. Stop the engine, set the park brake, remove the ignition key and wait for all moving parts to stop before dismounting.
4. Place a large block or safety stands under the deck to support the mower.
5. Remove the lynch pin on the caster shaft and lower the caster until it is out of it's socket.
6. Rearrange the spacers above and below the wheel beam for your desired deck height. Arrange all spacers equally on all 4 casters.
7. Ensure all lynch pins are secure.
8. Remove the blocks or safety stands.

### 1. Operating Tips:

2. Although it is best to cut when it is dry, the Mower will work in wet conditions as well. The operator will have to travel slower for the same quality of cut. It will also be necessary to clean the bottom of the deck more frequently to prevent caking or clogging of the blade area.
3. Cutting should always be done at the rated PTO speed of 540 RPM. The cutting action is generated at the blade tips. When the speed drops below a certain point the blade will start to tear the material rather than cut it. It will look uneven and ragged.
4. Change gears to vary the ground speed. For your safety do not travel faster than 4 MPH (6 km/h). It is the operator's responsibility to operate the machine in a safe manner at all times.
5. If the grass is tall, cut it twice to obtain the best results. This allows the unit to cut less material on each pass.
6. When mowing a new area for the first time, you may want to set the deck height higher to clear any objects that may be hidden in long grass. When you are familiar with the area and have not detected any foreign objects the mower height can be set to the preferred cutting height.
7. Never cut grasses shorter than recommended for your weather conditions. Short grass is less able to withstand hot and dry conditions. It is better to cut more frequently at a longer length than cutting too short.
8. The blades need sharpening when the grass is not cut evenly and appears to be ripped off rather than a clean cut.
9. Reduce ground speed when mowing in close quarters and around obstructions.
10. The mower should always be operated with all 4 wheels on the ground. The mower may be lifted a few inches off the ground when maneuvering around corners or objects.
11. The mower has three blades that turn at a high rate of speed and can expel objects out of the discharge area, 50 ft or more. It is important that the operator is aware of this and never points the mower discharge towards people, animals or property. It is better to stop cutting when people are in the area, especially children.



## 48 - 72 Pulsar Finish Mower Parts

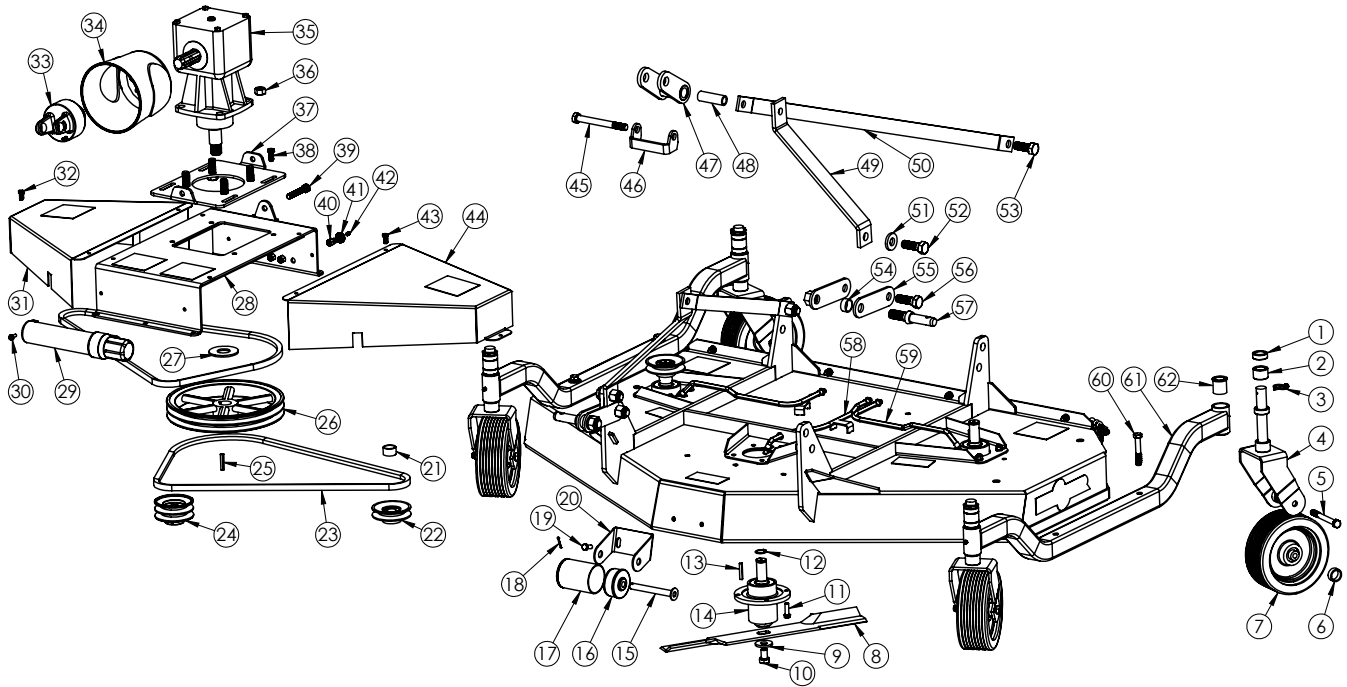

Item #	Part #	Description	Qty 48	Qty 60	Qty 72
1	53537	Short spacer	8	8	8
2	53536	Long spacer	8	8	8
3	OL	3/16 Lynch pin	4	4	4
4	53245	Wheel fork	4	4	4
5	OL	Bolt 1/2 x 4 1/2 c/w ln	4	4	4
6	53337	Wheel spacer	8	8	8
7	53670	Wheel	4	4	4
8	176004	48 Blades	3		
	176009	60 Blades		3	
	900007	72 Blades			3
9	10118	Heavy washer	3	3	3
10	OL	Bolt 5/8 x 1 c/w lw	3	3	3
11	OL	Bolt 3/8 x 1 1/4 c/w lw,n	12	12	12
12	1400-100	Snap ring	3	3	3
13	21397	Short keystick	2	2	2
14	900001	Spindle	3	3	3
15	21399	Scalp roller axle	1	1	1
16	53671	Scalp roller end	2	2	2
17	10304	Scalp roller body	1	1	1
18	OL	Cotter pin 1/8 x 1	1	1	1
19	OL	Bolt 3/8 x 1 c/w fw,ln	2	2	2

## 48 - 72 Pulsar Finish Mower Parts

Item #	Part #	Description	Qty 48	Qty 60	Qty 72
20	53267	Roller bracket	1	1	1
21	21392	Pulley spacer	2	2	2
22	900008	48 Outside spindle pulley	2		
	900010	60 Outside spindle pulley		2	
	900004	72 Outside spindle pulley			2
23	Belt58	48 Belt	2		
	Belt68	60 Belt		2	
	Belt78	72 Belt			2
24	900009	48 Center spindle pulley	1		
	900011	60 Center spindle pulley		1	
	900003	72 Center spindle pulley			1
25	21395	Long keystick	2	2	2
26	900002	Gearbox pulley	1	1	1
27	OL	1 1/4 Flatwasher	1	1	1
28	53260	Gearbox mount	1	1	1
29	DJA7011	Manual tube	1	1	1
30	OL	Bolt 1/4 x 1 self drilling screw	2	2	2
31	53252	48 Right belt cover	1		
	53292	60 Right belt cover		1	
	53559	72 Right belt cover			1
32	OL	Bolt 5/16 x 3/4 c/w lw	2	2	2
34	DJA69351	PTO shield	1	1	1
35	LF205J808	Gearbox	1	1	1
36	OL	5/8 Nut c/w lw	4	4	4
37	53267	Gearbox slider	1	1	1
38	OL	Bolt 3/8 x 1 c/w lw,fw,n	10	10	10
39	OL	Bolt 1/2 x 3 Full thread c/w ln	1	1	1
43	OL	Bolt 5/16 x 3/4 c/w lw	4	4	4
44	53252	48 Left belt cover	1		
	53291	60 Left belt cover		1	
	53558	72 Left belt cover			1
45	OL	Bolt 5/8 x 6 c/w ln	1	1	1
46	53314	Top link stop	1	1	1
47	53236	Top link	1	1	1
48	53237	Top link bushing	1	1	1
49	53234	A frame	2	2	2
50	53235	48 A frame brace bar	2		
	53290	60 A frame brace bar		2	
	53557	72 A frame brace bar			2
51	53264	Stop washer	2	2	2



### 48 - 72 Pulsar Finish Mower Parts cont.

Item #	Part #	Description	Qty 48	Qty 60	Qty 72
52	OL	Bolt 3/4 x 2 1/4 c/w In	2	2	2
53	OL	Bolt 3/4 x 2 c/w In	2	2	2
54	21401	Spacer	2	2	2
55	53232	Hitch link	4	4	4
56	OL	Bolt 3/4 x 2 1/4 c/w In	2	2	2
57	53061	Hitch pin c/w lw,n	2	2	2
60	OL	Bolt 1/2 x 3 c/w lw,fw	4	4	4
61	53240	48 Wheel beam	2		
	53295	60 - 72 Wheel beam		2	2

**Note**

**OL - Obtain Locally**  
**c/w - Complete With**  
**fw - Flatwasher**  
**lw - Lockwasher**  
**In - Locknut**  
**n - Nut**

## 90 Pulsar Finishing Mower Parts

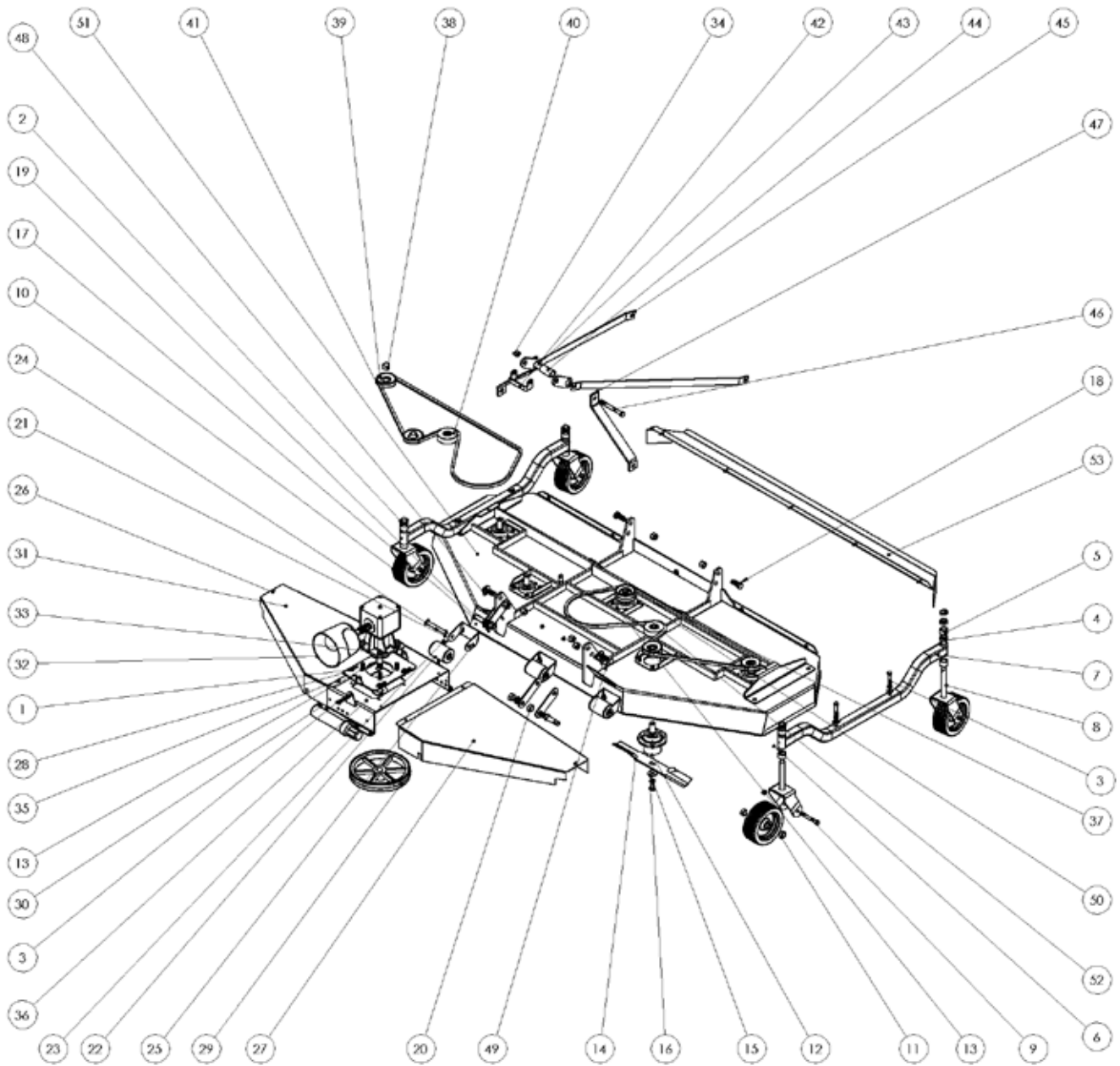

Item #	Part #	Description	Qty
1	OL	Bolt 3/8 x 1 c/w lw, n	5
2	OL	3/16" Lynch Pin	4
3	OL	Bolt 1/2 x 3 c/w fw, lw	4
4	53537	Short Spacer	8
5	53536	Long Spacer	8
6	OL	1/4 - 28 Grease Fitting	4
7	36727	90 Wheel Beam	2
8	53245	Wheel Fork	4
9	OL	Bolt 1/2 x 4 1/2 c/w ln	4
10	53670	Wheel	4
11	53337	Wheel Spacer	8
12	mkfm900001	Spindle	5

### 90 Pulsar Finishing Mower Parts cont.

Item #	Part #	Description	Qty
13	OL	Bolt 3/8 x 1 1/4 c/w lw, n	20
14	walfm900005	90" Blades	5
15	10118	Heavy Washer	5
16	OL	Bolt 5/8 x 1 c/w ln	5
17	53061	Hitch Pin c/w lw, n	2
18	OL	Bolt 3/4 x 2 c/w ln	2
19	53232	Hitch Link	4
20	21401	Spacer	2
21	OL	1/8 x 1 Cotter Pin	3
22	21400	Complete Scalp Roller	3
23	OL	Bolt 3/8 x 1 c/w lw, fw, ln	6
24	21399	Scalp Roller Axle	3
25	53267	Roller Bracket	3
26	OL	5/16 x 3/4 c/w lw	2
27	36170	90 Left Belt Cover	1
28	53229	Gearbox Slider	1
29	mkfm900002	Gearbox Pulley	1
30	DJA70111	Manual Tube	1
31	36173	90 Right Belt Cover	1
32	DJA69351	PTO Shield	1
33	cnxLF205J808	LF 205 Gearbox	1
34	OL	5/8 Nut c/w lw	4
35	OL	5/16 x 3/4 c/w lw	4
36	53260	Gearbox Mount	1
37	1400-100	Snap Ring	5
38	21392	Pulley Spacer	4
39	mkfm900010	90 Outside Spindle Pulley	4
40	36188	Idler Pulley	2
41	beltB110	90 Mower Belt	2
42	53314	Top Link Spacer	1
43	53237	Top Link Bushing	1
44	53239	Top Link	1
45	53557	A-Frame Brace Bar	2
46	OL	Bolt 5/8 x 6 c/w ln	1
47	53234	A-Frame	2
48	53264	Stop Washer	2
49	OL	Bolt 3/4 x 3 1/4 c/w ln	2
50	mkfm900011	90 Inside Spindle Pulley	1
51	36167	Main Body Assembly	1
52	OL	20mm External Snap Ring	2
53	36519	Rear Shield	1

## 48 - 72 Pulsar Finish Mower Rear Shield

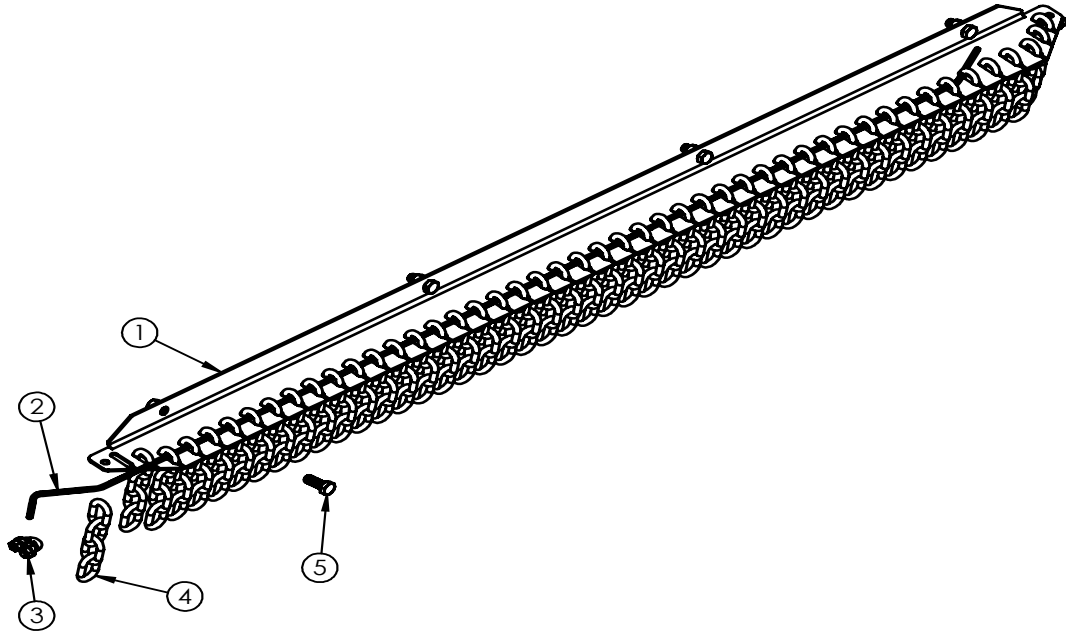

Item #	Part #	Description	Qty 48	Qty 60	Qty 72
1	53545	48 Rear deflector	1		
	53539	60 Rear deflector		1	
	53560	72 Rear deflector			1
2	53546	48 Holder cable	1		
	53538	60 Holder cable		1	
	53561	72 Holder cable			1
3	OL	3/16 Cable clamp	2	2	2
4	53081	Chain	37	47	55
5	OL	Bolt 3/8 x 1 c/w lw,n	4	4	4

## 42-72 Belt Arrangement for Pulsar Finish Mower

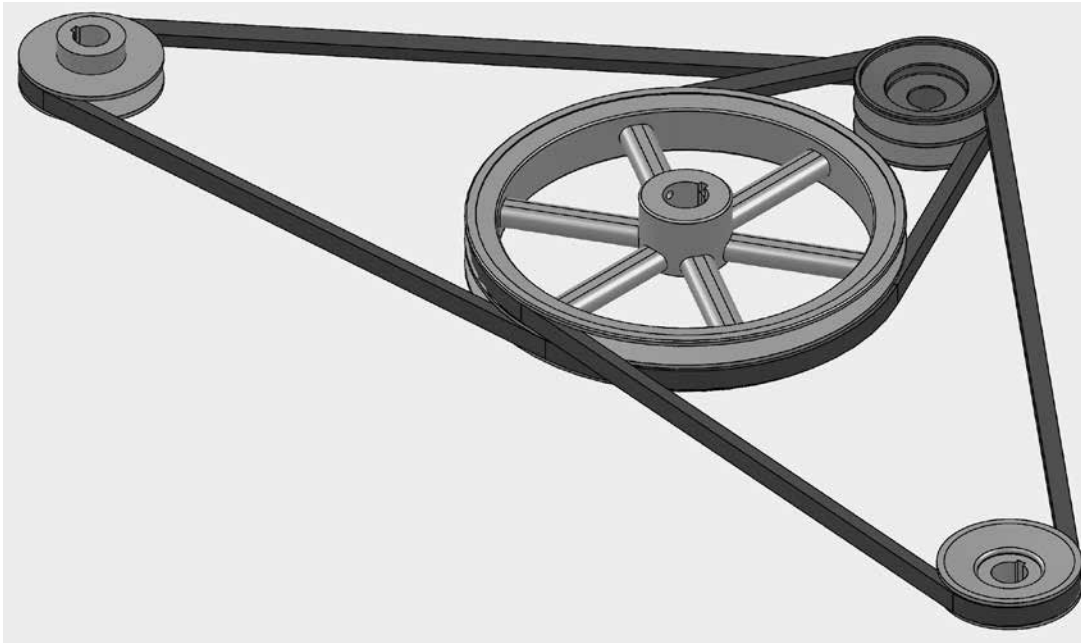

## 90 Belt Arrangement for Pulsar Finish Mower



All of the Pulsar Finish Mowers have a similar belt arrangement

### Note:

The two single V-Pulleys are identical, only one of them is upside down. For the 42-72 it does not matter which pulley is right side up. There is a spacer on the spindle that is either below or on top of the pulley. For the 90 the Idler Spindles have one that sits higher than the other, therefore making setup of the other spindles to be higher or lower on the same side the Idler Spindles are. They are held in place with a snap-ring and set screws.

When tightening the belt please note after a certain tension the gearbox bracket starts to deflect and the large pulley starts to angle, causing belt misalignment. **Please do not tighten beyond this point!** Do not use any form of belt dressing, as this causes the belts to become glazed or the dressing stays tacky and will collect dust and debris.

# LF-205-808 Gearbox

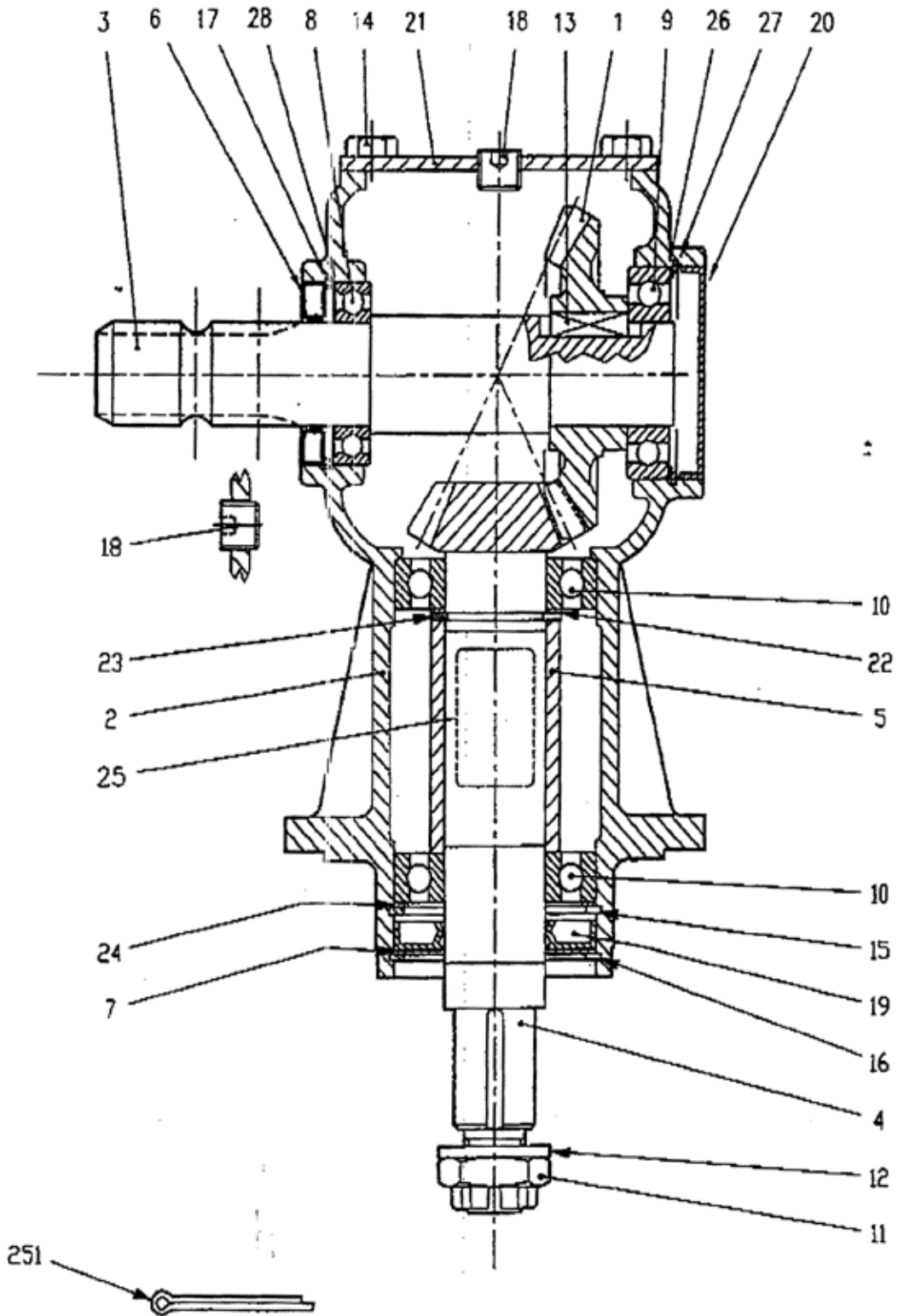

## LF-205-808 Gearbox

Item #	Part #	Description	Qty
1	0.135.5000.00	Crown Gear Z23 MS	1
2	0.205.030.00	Casting	1
3	0.135.2003.00	Input Shaft	1
4	0.125.6013.00	Pinion	1
5	0.125.7105.00	Spacer	1
6	8.0.1.00000	Oil Seal 35x62x7	1
7	1.125.7100.00	Protective Washer	1
8	8.0.1.00000	Bearing 6007 (35x62x14)	1
9	8.0.1.00870	Bearing 6207 (35x82x17)	1
10	8.0.1.00871	Bearing 6208 (40x80x18)	2
11	8.2.2.01144	Castle Nut M24x2	1
12	8.3.2.00409	Washer (25x44x4)	1
13	8.4.1.0093	Parallel Key (10x8x30)	1
14	8.1.1.00054	Bolt (M10x20)	4
15	8.5.2.00030	Snap Ring (80x83x2.5)	1
16	8.5.3.00955	Snap Ring (SB81)	1
17	8.5.2.00648	Snap Ring (62x65x3)	1
18	8.6.6.00301	3/8" Plug	2
19	8.7.1.00748	Dust Lip (40x80x12)	1
20	8.7.0.00744	Oil Cap (72x10)	1
21	0.205.1300.00	Cover	1
22	0.244.7500.00	Shim Kit (40.3x51.5)	1
23	8.5.1.00680	(Snap Ring 40x37.5x2.5)	1
24	0.248.7500.00	Shim Kit (69x79.7)	1
25	0.124.71.35.00	Name Plate	1
26	0.113.7500.00	Shim Kit (55.4x61.7)	1
27	8.5.2.00131	Snap Ring (72x75x25)	1
28	0.113.7500.00	Shim Kit (55.4x61.7)	1
251	8.4.7.00516	Cotter Pin	1

### Note

**OL - Obtain Locally**  
**c/w - Complete With**  
**fw - Flatwasher**  
**lw - Lockwasher**  
**ln - Locknut**  
**n - Nut**

## PTO Drive-line Dimension

**The PTO Drive-line as supplied with the machine will need to be checked for the proper length before being put into service.**

To accommodate the various hitch and tractor configurations the supplied shaft may be too long, or in some cases too short. To determine shaft length, find the collapsed length, raise or lower the equipment until the PTO out of the tractor is horizontal with the input shaft on the machine. Measure lock-pin groove to lock-pin groove or bolt hole on the equipment. If this is on trailed equipment then turn tractor as sharp as possible.

Measure collapsed PTO shaft from lock-pin to lock-pin or bolt hole and compare it with the measurement on the tractor. The difference of these measurements needs to be cut from Both Halves of the PTO shaft plus 1/2".

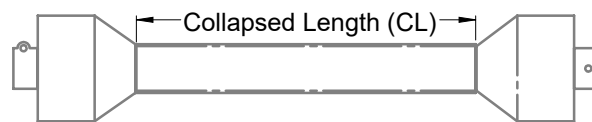

**Working Length overlap is 1/2 of above collapsed length**

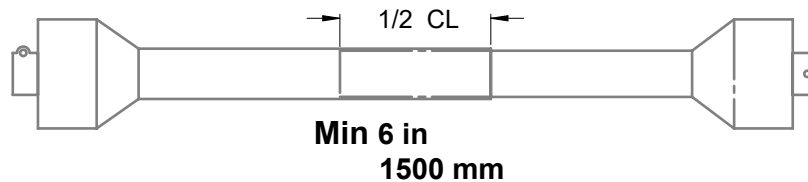

**Minimum Overlap in Transport Position 1/3 of collapsed length**

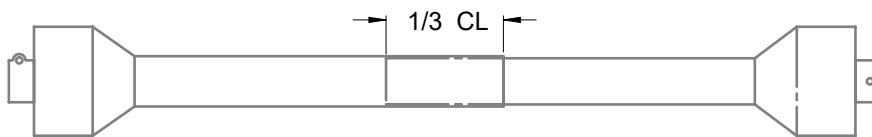

**Following these guidelines will reduce the chances of damage to the equipment.**

- Use a sharp hacksaw to cut the PTO tube
- Use a fine file to remove any sharp edges and burrs from sawing
- Clean off all dirt and filings from tube , carefully test for smooth fit.
- Apply a light coat of grease to the outside of the small tube
- Reinstall the shields
- Install on equipment and recheck

**These procedures need to be done before first putting into operation and when attaching to a different tractor**



# PTO 48-72 NA

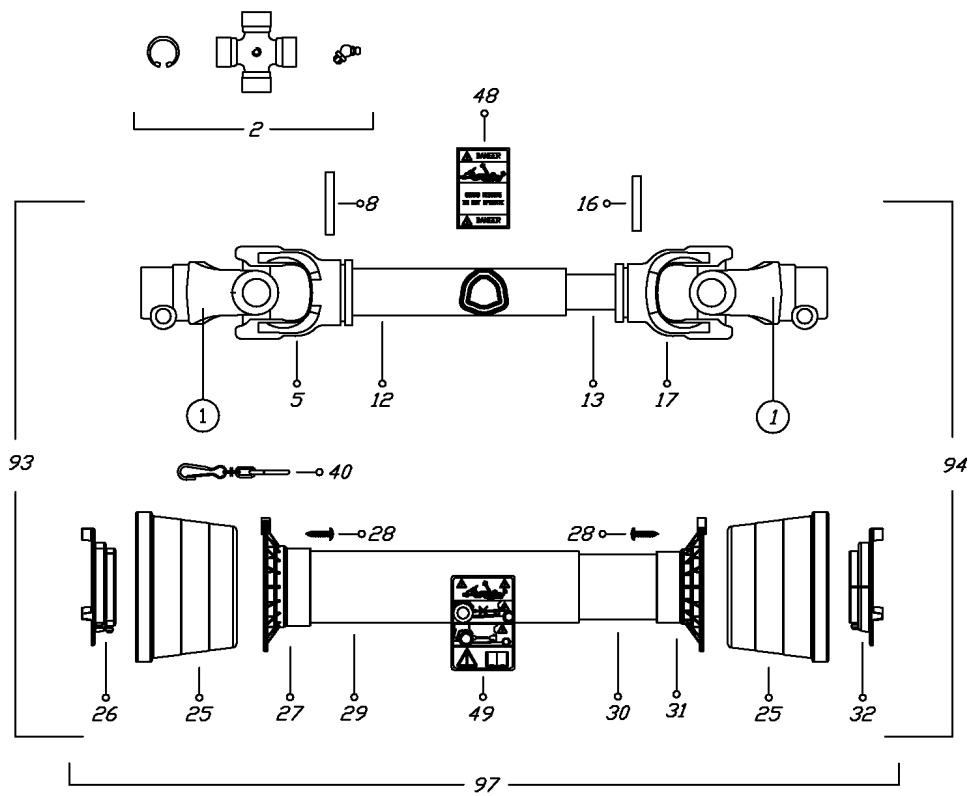

①

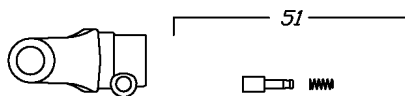

Item #	Part #	Description	Qty
1	0800203	Yoke 1 3/8" Z6	2
2	08202	Cross Journal Assy	2
5	08002021	Outer Tube Yoke	1
8	098700855	Spring Pin 8x55 mm	1
12	09881363100	CM 100 Cardan Tube 02 E 36x3,2	1
13	09881294100	CM 100 Cardan Tube 02 I 29 x4	1
16	098700850	Spring Pin 8x50 mm	1
17	08002011	Inner Tube Yoke	1
25	021902C001	Cone Shield Bell 01-02	2
26	025502C001	Outer Bearing 02	1
27	025402C001	Outer Base Cone 01-02	1
28	0998052242	Screw	6
29	0988961NB2081	Outer Safety Shield Tube	1
30	0988955NB2081	Inner Safety Shield Tube	1
31	025402C002	Inner Base Cone 01-02	1
32	025502C002	Inner Bearing 02	1
40	025000001	Chain	1
48	09872006	Drive Tube Danger Label	1
49	09872003	External Shield Label	1
51	0986014047	Complete Push Button	1

## PTO 84-90 B4

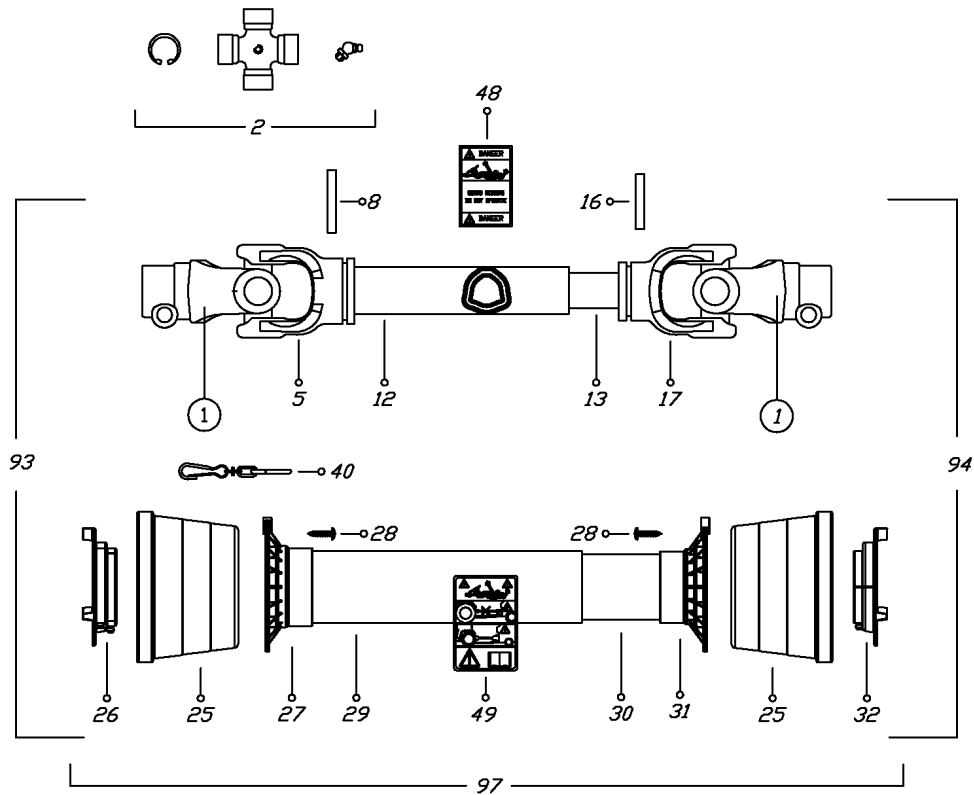

①

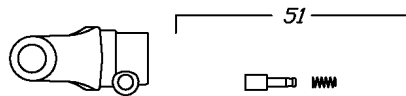

Item #	Part #	Description	Qty
1	0800403	Yoke 1 3/8" Z6	2
2	08204	Cross Journal Assy	2
5	08004021	Outer Tube Yoke	1
8	098700860	Spring Pin 8x60 mm	1
12	09881433100	CM 100 Cardan Tube 04 43x3 M1	1
13	09881364100	CM 100 Cardan Tube 04 36x4.5 M1	1
16	098700855	Spring Pin 8x55 mm	1
17	08004011	Inner Tube Yoke	1
25	021904C001	Cone Shield Bell 03-04	2
26	025504C001	Outer Bearing 03-04	1
27	025404C001	Outer Base Cone 03-04	1
28	0998052242	Screw	6
29	0988966NB4086	Outer Safety Shield Tube	1
30	0988961NB4086	Inner Safety Shield Tube	1
31	025404C002	Inner Base Cone 03-04	1
32	025504C002	Inner Bearing 03-04	1

40	0252000001	Chain	1
48	09872006	Drive Tube Danger Label	1
49	09872003	External Shield Label	1
51	0986014047	Complete Push Button	1

## Bolt Torque

As used on this machine

- Bolt torque table shown below gives torque values for various bolts used.
- This chart is for non-lubricated threads.
- Replace with same strength bolt.

Torque Specifications. Torque values are identified by their head markings.

Diameter	SAE 2		SAE 5		SAE 8	
	<i>ft-lb</i>	<i>N.m</i>	<i>ft-lb</i>	<i>N.m</i>	<i>ft-lb</i>	<i>N.m</i>
<b>"A"</b>						
<b>1/4</b>	6	(8)	8	(11)	12	(16)
<b>5/16</b>	11	(15)	17	(24)	25	(33)
<b>3/8</b>	20	(27)	31	(42)	44	(59)
<b>7/16</b>	32	(43)	49	(67)	70	(95)
<b>1/2</b>	49	(66)	76	(105)	105	(145)
<b>5/8</b>	97	(130)	150	(205)	210	(285)
<b>3/4</b>	144	(195)	265	(360)	375	(510)
<b>7/8</b>	165	(225)	430	(585)	605	(820)
<b>1</b>	250	(340)	645	(875)	910	(1230)
<b>1 1/8</b>	355	(480)	795	(1080)	1290	(1750)
<b>1 1/4</b>	500	(680)	1120	(1520)	1820	(2460)
<b>1 1/2</b>	870	(1180)	1950	(2640)	3160	(4290)

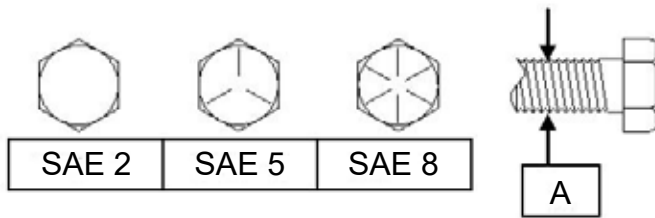

Allen head cap screw are similar to SAE 8 quality

These torques are for reference only. Not all these sizes and grades are necessarily used in this machine. Bolts that are used as a pivot or hinge have to be used with a locknut, therefore only tighten enough to secure the bolt and still allowing the part to rotate freely.

## Maintenance

**Good maintenance is your responsibility. Poor maintenance is an invitation for trouble.**

Check for missing paint and scratches, prime and paint to keep the metal from rusting.

Replace any caution, warning, danger or instruction safety decal that is not readable or is missing.

The servicing periods are based on normal operating conditions. Severe or unusual conditions may require more frequent lubrication or oil changes.

### 8 Hours or Daily

1. Lubricate PTO drive-line (4 locations)
2. Lubricate Castor Shafts (4 Locations)
3. Check Belt Tension

### 20 Hours

Lubricate PTO drive-line (3 locations)

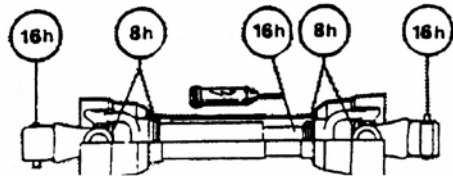

**PTO Drive-line**

### 40 Hours

1. Check gearbox oil level. Add 80W-90 oil as required.
2. Lubricate wheels (4 locations)
3. Check belt condition ( cracked, frayed etc)

### Annually

Wash Machine before storing



MK Martin Enterprise Inc.  
3950 Steffler Rd Elmira, ON, Canada N3B 2Z3

Tel: 519-664-2752  
Toll Free: 1-855-664-2752  
Fax: 519-664-3695  
E-mail: [sales@mkmartin.ca](mailto:sales@mkmartin.ca)  
[www.mkmartin.ca](http://www.mkmartin.ca)